

073206T4BLD

BUILDING TECHNICIAN LEVEL 6

CON/OS/BUT/CR/03/6

PRODUCE MASONRY UNITS.

July/August 2024



**TVET CURRICULUM DEVELOPMENT, ASSESSMENT AND CERTIFICATION
COUNCIL (TVET CDACC)**

PRACTICAL ASSESSMENT

TIME: 4 HOURS

INSTRUCTIONS TO CANDIDATE

In this assessment, you are required to complete the following tasks:

- a. Produce 5 pieces of concrete blocks of sizes 450 x 200 x 225 mm as shown in Figure 1 below using class 20 concrete

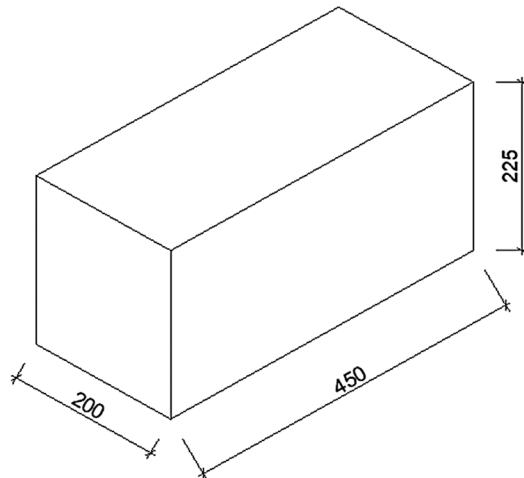

Figure 1

You are provided with the following resources to carry out the tasks:

Tools and equipment	Materials
<ul style="list-style-type: none">• Mold (450x200x225mm)• Spade• Steel float• Wood float• Tamping rod• PPEs (gloves, 1overall, safety boots)• Trowel	<ul style="list-style-type: none">• Quarry dust• Sand• Cement• Lime• Water.

easyvet.com